

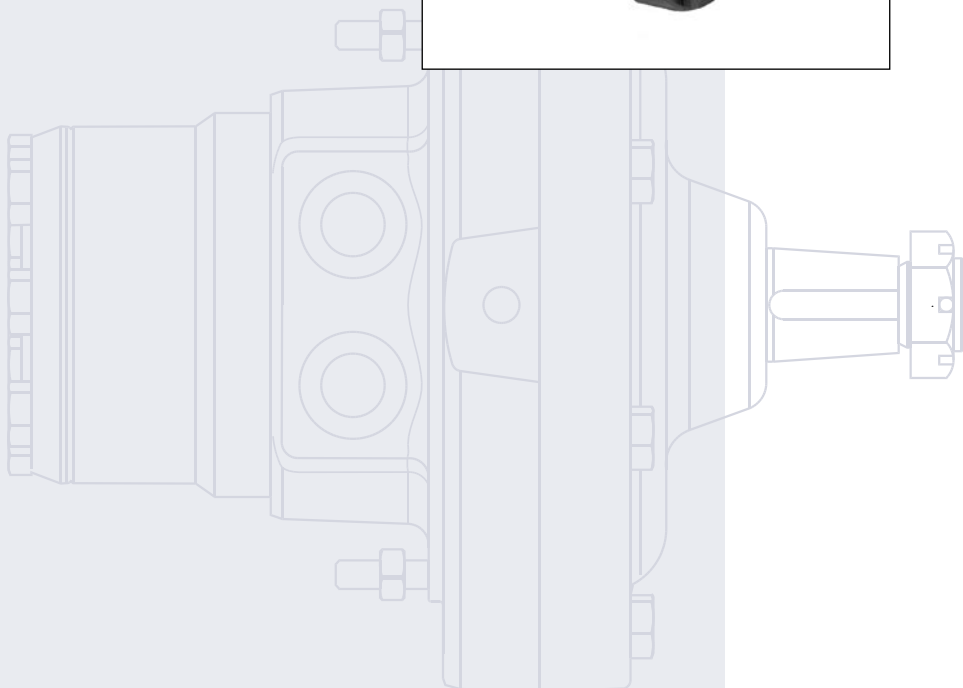

OMEW F

Orbital motors

Tech Note

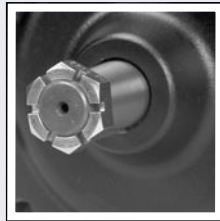
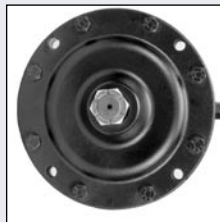

INTRODUCTION	Introduction	2
VERSIONS	Versions.....	2
CODE NUMBERS	Code numbers.....	2
TECHNICAL DATA	Technical data.....	2
	Max. permissible shaft seal pressure	7
	Pressure drop in motor.....	8
	Direction of shaft	8
	Permissible shaft loads for OMEW F	9
	Shaft version	10
	Port thread version	10
DIMENSIONS AND WEIGHTS	Dimensions and weights	11

© 2004 Sauer-Danfoss. All rights reserved. Printed in Europe

Sauer-Danfoss accepts no responsibility for possible errors in catalogs, brochures and other printed material. Sauer-Danfoss reserves the right to alter its products without prior notice. This also applies to products already ordered provided that such alterations aren't in conflict with agreed specifications. All trademarks in this material are properties of their respective owners. Sauer-Danfoss and the Sauer-Danfoss logotype are trademarks of the Sauer-Danfoss Group.

Front cover illustrations: F301076, F301077, F301078, F301079
Drawing: 151-2045

INTRODUCTION

Sauer-Danfoss now offers OMEW motors with an integrated parking brake, making them even more ideal as transmission motors in small vehicles.

The OMEW F motor is specially designed for scissor lifts, but is also suitable for a wide range of other vehicle applications that require a motor that is both compact and highly efficient. Characteristic features that distinguish the OMEW F motor are:

- Compact design
- Low weight
- High total efficiency
- High starting torque
- Smooth low speed performance
- Large bearing capacity
- High pressure shaft seal
- No drain line
- Black paint standard
- Integrate parking brake

Versions

Mounting flangeM	Shaft	Port size	European version	US version	Clockwise shaft rotation (CW version) ¹⁾	counter clockwise shaft rotation (CCW version) ¹⁾	Flange port version	Standard shaft seal	Drain connection	Check valve	Specials	Main type designation
Wheel brake	Tapered 1.25 in	³ / ₄ - 16 UNF		○	○		○		○	No	No	OMEW F
	Tapered 1.25 in	³ / ₄ - 16 UNF		○		○	○		○	No	No	OMEW F

1) Direction of rotation

If the application mainly involves operation in one direction, we recommend the corresponding motor with either CW- or CCW-rotation, which will optimize seal life.

Since all OMEW F motors are fitted with a high-pressure shaft seal, there is no need for a drain line.

Motors are painted black

Code numbers

	Code numbers	Displacement (cm ³)							Technical data - page	Dimensions - page	
		100	125	160	200	250	315	345			400
→	151H	3060	3061	3062	3063	3064	3065	3066	3067	6	11
→	151H	3070	3071	3072	3073	3074	3075	3076	3077	6	11

Ordering

Add the four digit prefix "151H" to the four digit numbers from the chart for complete code number.

Example:

151H3064 for an OMEW F 250 with 1.25 in tapered shaft, port size 3/4 - 16 UNF and clockwise rotation (CW).

Orders will not be accepted without the four digit prefix

Technical data for OMEW F with 1 1/4 in tapered shaft

Type	Motorsize		OMEW F 100	OMEW F 125	OMEW F 160	OMEW F 200	OMEW F 250	OMEW F 315	OMEW F 345	OMEW F 400
Geometric displacement	cm ³ in ³		99.8 [6.11]	124.1 [7.60]	155.4 [9.51]	198.2 [12.13]	248.1 [15.18]	310.1 [18.98]	341.8 [20.86]	390.7 [23.83]
Max. Speed	min-1 (rpm)	cont.	600	475	375	300	240	190	175	150
		int. ¹⁾	750	695	470	375	300	240	220	190
Max. torque	N•m [lbf•in]	cont.	250 [2210]	320 [2830]	410 [3630]	400 [3540]	470 [4160]	550 [4868]	610 [5400]	700 [6195]
		int. ¹⁾	270 [2390]	340 [3010]	430 [3810]	570 [5045]	710 [6284]	850 [7523]	860 [7612]	870 [7700]
Max. output	kW [hp]	cont.	12 [16.1]	12 [16.1]	12 [16.1]	11 [14.75]	10 [13.41]	9 [12.07]	9 [12.07]	9 [12.07]
		int. ¹⁾	15 [20.1]	15 [20.1]	15 [20.1]	16 [21.5]	16 [21.5]	15 [20.1]	14 [18.8]	12 [16.1]
Max. pressure drop	bar [psi]	cont.	200 [2900]	200 [2900]	200 [2900]	150 [2175]	140 [2030]	130 [1885]	130 [1885]	130 [1885]
		int. ¹⁾	210 [3050]	210 [3050]	210 [3050]	210 [3045]	210 [3045]	200 [2900]	185 [2683]	160 [2320]
Max. oil flow		cont.	60 [15.9]	60 [15.9]	60 [15.9]	60 [15.9]	60 [15.9]	60 [15.9]	60 [15.9]	60 [15.9]
		int. ¹⁾	75 [19.8]	75 [19.8]	75 [19.8]	75 [19.8]	75 [19.8]	75 [19.8]	75 [19.8]	75 [19.8]
Max. starting pressure with unloaded shaft	bar [psi]		10 [145]	7 [100]	7 [100]	7 [100]	7 [100]	7 [100]	7 [100]	7 [100]
Min. starting torque	N•m [lbf•in]	at max. press. drop cont.	230 [2040]	290 [2570]	360 [3190]	330 [2920]	390 [3451]	460 [4071]	500 [4425]	580 [5133]
		at max. press. drop int. ¹⁾	240 [2120]	300 [2660]	380 [3360]	470 [4160]	580 [5133]	700 [6195]	710 [6284]	710 [6284]

Type			Max. inlet pressure	Max. return pressure
OMEW F 100 - 400	bar [psi]	cont.	200 [2900]	200 [2900]
	bar [psi]	int. ¹⁾	210 [3050]	210 [3050]
	bar [psi]	peak ²⁾	225 [3260]	225 [3260]

1) Intermittent operation: the permissible values may occur for max. 10% of every minute.

2) Peak load: the permissible values may occur for max. 1% of every minute.

Technical data for brake motor OMEW F	
Holding torque ¹⁾	840 N•m [7435 lbf•in]
Min. release pressure	17 bar [245 psi]
Max. pressure in brake line	225 bar [3260 psi]

¹⁾ This brake is to be used only as a passive parking brake. It may not be used for dynamic braking.

When the pressure in the brake release line is greater than 2 bar [29 psi], the holding torque depends inversely proportional on the actual pressure in the brake release line.

At ≤ 2 bar [29 psi] - holding torque = 840 N•m [7453 lbf•in]

At ≥ 17 bar [245 psi] - holding torque = 0 N•m [0 lbf•in]

**MAX. PERMISSIBLE
SHAFT SEAL PRESSURE**

OMEW F with high pressure shaft seal

CW version (clockwise rotation)

- 1) With clockwise rotation:
The shaft seal pressure equals the return pressure.
- 2) With counter clockwise rotation:
The shaft seal pressure equals the input pressure

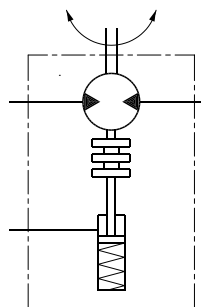

151-2049.10

CCW version (counter clockwise rotation)

- 1) With counter clockwise rotation:
The shaft seal pressure equals the return pressure.
- 2) With clockwise rotation:
The shaft seal pressure equals the input pressure

Max. permissible shaft seal pressure

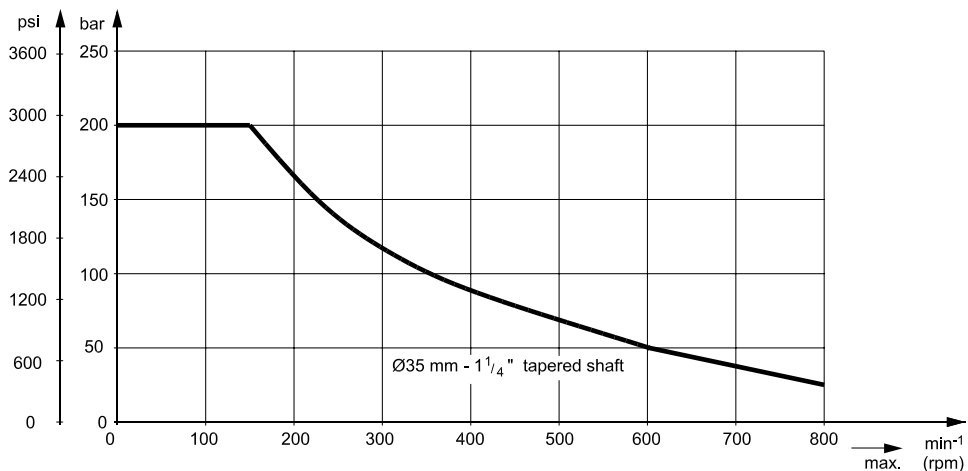

151-1861.10

**PRESSURE DROP IN
MOTOR**

A: OMEW F 100 - 160
B: OMEW F 200 - 400

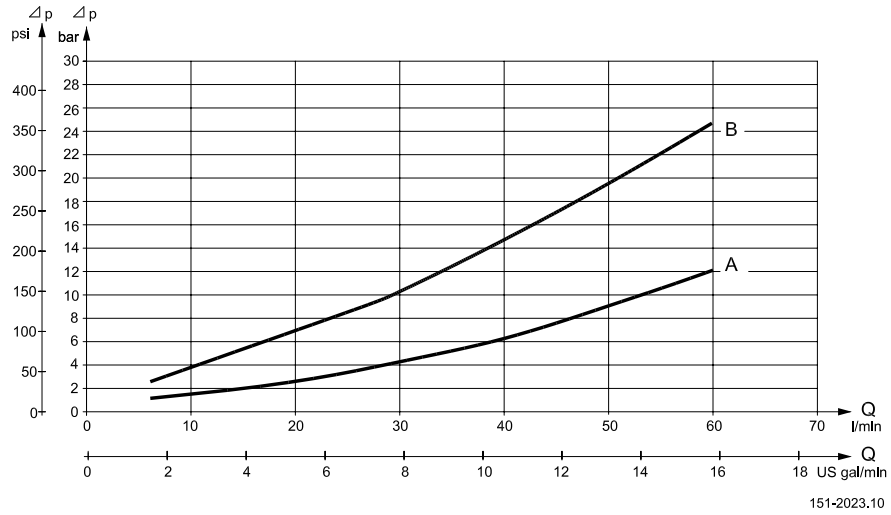

The curve applies to an unloaded motor shaft and an oil viscosity of 35 mm²/s [165 SUS]

**DIRECTION OF SHAFT
ROTATION**

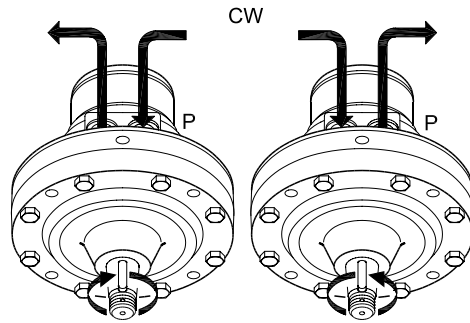

151-2051.10

CW - motor

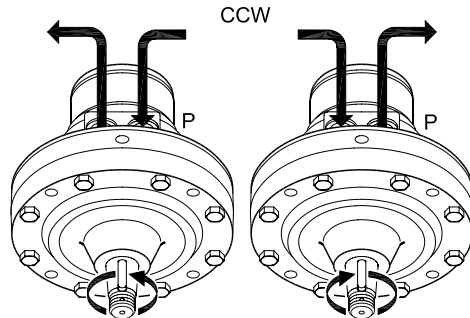

151-2052.10

CCW - motor

**PERMISSIBLE SHAFT
LOADS FOR OMEW F**

Due to the position of the output shaft bearings in relation to the mounting flange, it is possible to position a wheel hub on the shaft so that the radial load acts midway between the two needle bearings.

Based upon the requested max. speed and the point of action of the radial load the permissible shaft load can be read from the curved shown below.

Curve A shows the max. radial load. If the radial load exceeds these values there is a potential risk of breakdown.

The other curves apply to a B10 bearing life of 2000 hours at the indicated speed when applying a hydraulic mineral oil with an adequate content of anti-wear additives.

The longevity can also be calculated by means of the "Bearing dimensions" instructions in the technical information »General« DKMH.PK.100.G3.02 520L0232.

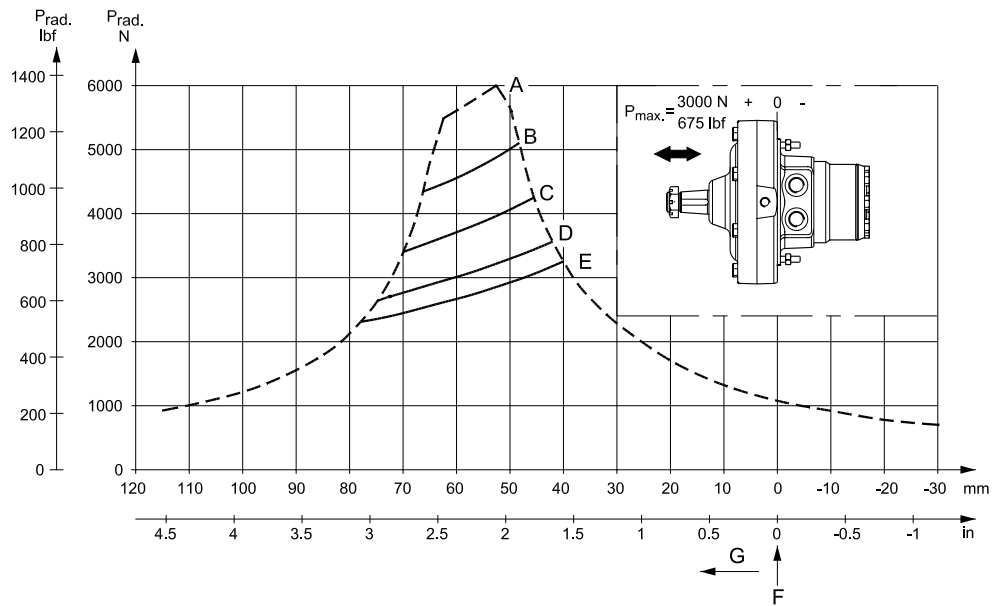

151-2050.10

- A: Max. radial load
- B: $n = 25 \text{ min}^{-1} \text{ (rpm)}$
- C: $n = 50 \text{ min}^{-1} \text{ (rpm)}$
- D: $n = 100 \text{ min}^{-1} \text{ (rpm)}$
- E: $n = 150 \text{ min}^{-1} \text{ (rpm)}$
- F: Front flange
- G: Direction toward shaft

SHAFT VERSION

- I: Tapered shaft 1.25 in shaft
- N: Cone 1:8
SAE J501
- M: 1 - 20 UNEF
Across flats 1 7/16 in
Tightening torque:
200 ± 10 N·m [1770 ± 85 lbf·in]
- G: Parallel key
5/16 × 5/16 × 1 1/4
SAE J501

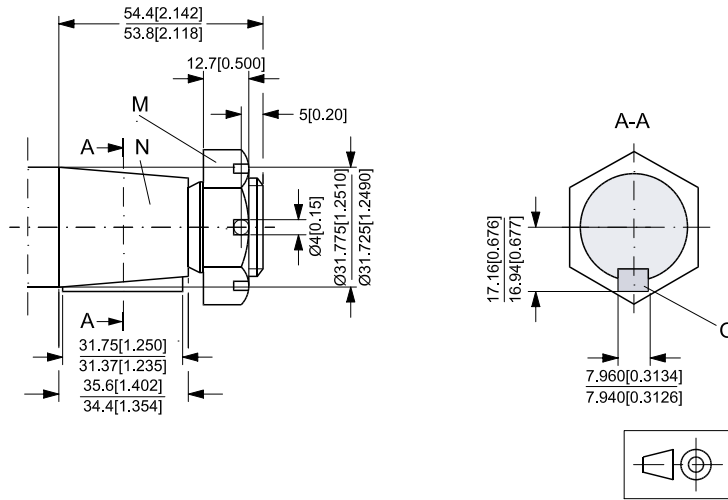

151-2047.10

PORT THREAD VERSION

- D: UNF main ports
- H: 3/4 - 16 UNF
- O-ring boss port

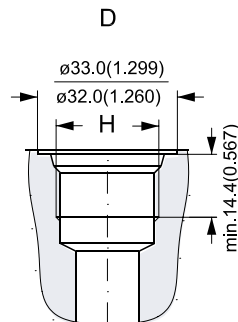

- C: UNF brake release port
- G: 7/16 - 20 UNF
- O-ring boss port

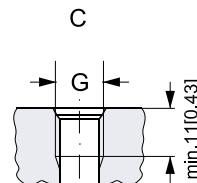

151-2048.10

DIMENSIONS

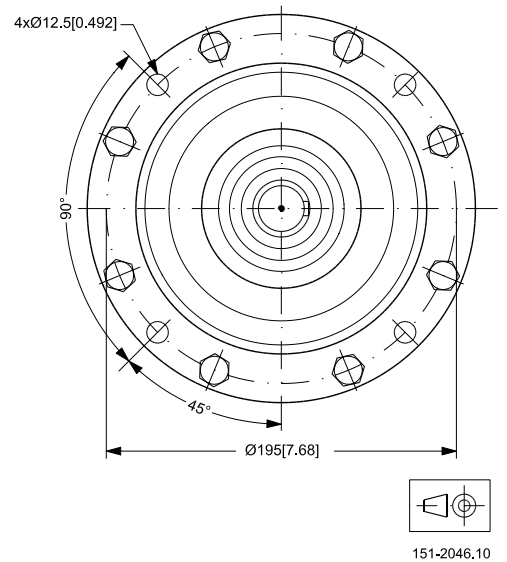
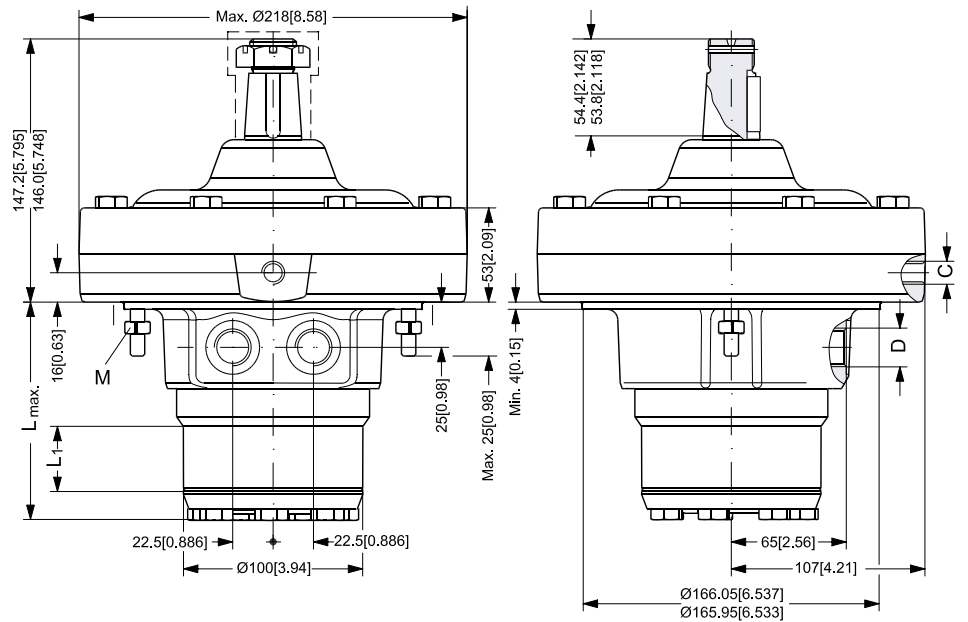

WEIGHT OF MOTORS

Type	Weight kg [lb]		Length	
			L_{max}	L_1
OMEW F 100	21.2	[46.7]	101.2 [3.98]	14.0 [0.55]
OMEW F 125	21.4	[47.2]	104.6 [4.12]	17.4 [0.67]
OMEW F 160	21.7	[47.8]	109.0 [4.29]	21.8 [0.86]
OMEW F 200	22.2	[48.9]	115.0 [4.53]	27.8 [1.09]
OMEW F 250	22.7	[50.0]	122.0 [4.80]	34.8 [1.37]
OMEW F 315	23.2	[51.1]	130.7 [5.15]	43.5 [1.71]
OMEW F 345	23.5	[51.8]	135.1 [5.32]	47.9 [1.89]
OMEW F 400	23.9	[52.7]	141.5 [5.57]	54.3 [2.12]

D: $\frac{3}{4}$ - 16 UNF, 14.4 [0.57 in] deep
C: $\frac{7}{16}$ - 20 UNF, 11.5 [0.45 in] deep

M: 2 x manual brake release (13 mm wrench)

----- Not painted

OUR PRODUCTS

Hydrostatic transmissions

Hydraulic power steering

Electro-hydraulic power steering

Electric power steering

Closed and open circuit axial piston pumps and motors

Gear pumps and motors

Bent axis motors

Orbital motors

Transit mixer drives

Planetary compact gears

Proportional valves

Directional spool valves

Cartridge valves

Hydraulic integrated circuits

Hydrostatic transaxles

Integrated systems

Fan drive systems

Electrohydraulic controls

Digital electronics and software

Electric motors and inverters

Sensors

Sauer-Danfoss Hydraulic Power Systems – Market Leaders Worldwide

Sauer-Danfoss is a comprehensive supplier providing complete systems to the global mobile market.

Sauer-Danfoss serves markets such as agriculture, construction, road building, material handling, municipal, forestry, turf care, and many others.

We offer our customers optimum solutions for their needs and develop new products and systems in close cooperation and partnership with them.

Sauer-Danfoss specializes in integrating a full range of system components to provide vehicle designers with the most advanced total system design.

Sauer-Danfoss provides comprehensive worldwide service for its products through an extensive network of Authorized Service Centers strategically located in all parts of the world.

Sauer-Danfoss (US) Company
2800 East 13th Street
Ames, IA 50010, USA
Phone: +1 515 239-6000, Fax: +1 515 239-6618

Sauer-Danfoss (Neumünster) GmbH & Co. OHG
Postfach 2460, D-24531 Neumünster
Krokamp 35, D-24539 Neumünster, Germany
Phone: +49 4321 871-0, Fax: +49 4321 871-122

Sauer-Danfoss (Nordborg) ApS
DK-6430 Nordborg, Denmark
Phone: +45 7488 4444, Fax: +45 7488 4400