

Technical  
Information

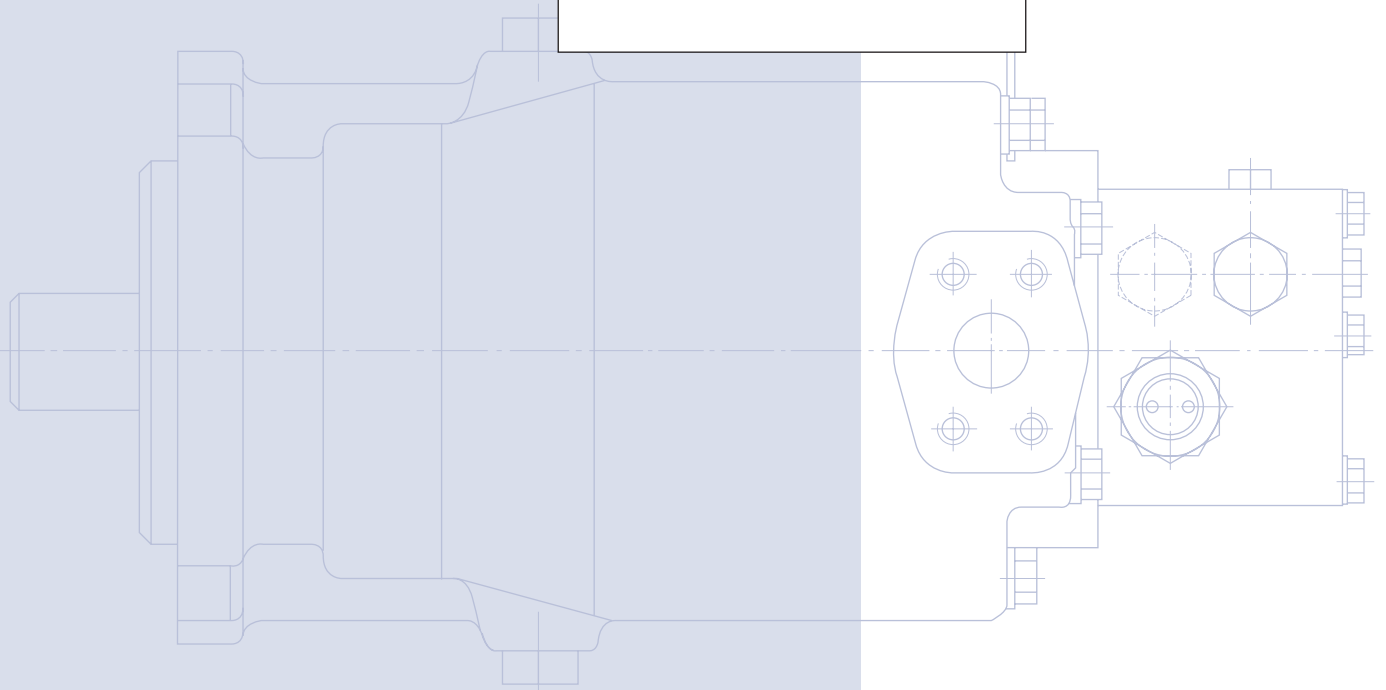
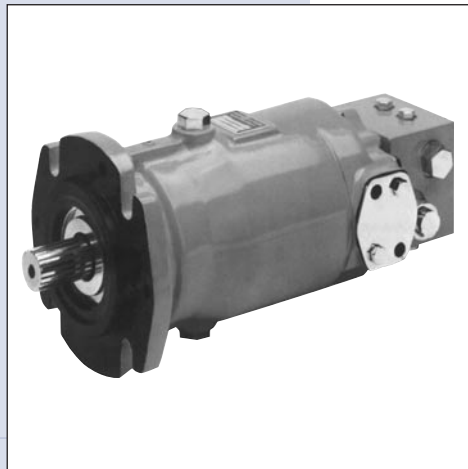
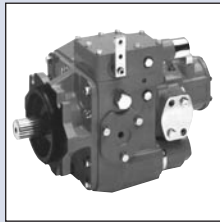
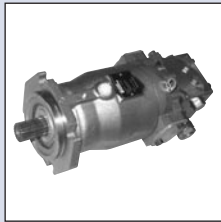

## INTRODUCTION

Sauer-Danfoss a world leader in hydraulic power systems has developed a family of axial piston motors.

## DESCRIPTION

Sauer-Danfoss axial pistons fixed displacement motors are of swash plate design with preset displacement suitable for hydrostatic transmissions with closed loop circuit.

The output speed is proportional to the motor's input flow.

The output torque is proportional to the differential pressure applied to the main pressure ports.

The direction of motor (output) shaft rotation depends on flow input to the main pressure ports.

Sauer-Danfoss axial piston fixed displacement motors are well engineered and easy to handle.

The full-length shaft with a highly efficient tapered roller bearing arrangement offers a high loading capacity for external radial forces.

High case pressures can be achieved without leakage even at the lowest temperatures by using suitable shaft seals.

Sauer-Danfoss axial piston units are designed for easy servicing. Complete dismantling and reassembly can be carried out with standard hand tools, and all components or sub-assemblies are replaceable.

Axial piston fixed displacement motors of the Sauer-Danfoss pattern are made by licensed producers worldwide, providing consistent service and fully inter-changeable parts.

## TYPICAL MARKETS

- Industrial
- Mining
- Transit Mixer
- Utility Vehicles

© 2002 Sauer-Danfoss. All rights reserved.

Sauer-Danfoss accepts no responsibility for possible errors in catalogs, brochures and other printed material. Sauer-Danfoss reserves the right to alter its products without prior notice. This also applies to products already ordered provided that such alterations aren't in conflict with agreed specifications. All trademarks in this material are properties of their respective owners. Sauer-Danfoss and the Sauer-Danfoss logotype are trademarks of the Sauer-Danfoss Group.

Front cover illustrations: P101 XXX, P101 XXX, P101 XXX, P101 XXX

<b>GENERAL DESCRIPTION</b>	Introduction .....	2
	Description .....	2
	Typical markets .....	2
<b>SECTIONAL VIEW</b>	Axial piston fixed displacement motor .....	4
<b>SYSTEM CIRCUIT DESCRIPTION</b>	Pump and motor circuit description .....	5
	Motor circuit schematic .....	5
<b>TECHNICAL SPECIFICATION</b>	Technical parameters.....	6
	Design .....	6
	Type of mounting .....	6
	Pipe connections .....	6
	Direction of rotation and flow.....	6
	Installation position .....	6
	External drain fluid loss .....	6
	Hydraulic parameters.....	7
	System pressure range, input $p_1$ .....	7
	System pressure range, output $p_2$ .....	7
	Case pressure .....	7
	Hydraulic fluid.....	7
	Hydraulic fluid temperature range.....	7
	Viscosity range.....	7
	Filtration.....	7
Shaft load.....	7	
Determination of nominal motor size.....	8	
<b>DIMENSIONS – FRAME SIZE 070 AND 089</b>	Outline drawing, configuration ms .....	9
	Outline drawing, basic model .....	11
	Outline drawing, motor configuration am 01000.....	11
	Outline drawing, motor configuration mr .....	12
	Circuit diadrams.....	13
	Configuration MR.....	13
	Basic model and motor configuration AM 01000 .....	13
<b>DIMENSIONS – FRAME SIZE 227 AND 334</b>	Outline drawing, configuration ms .....	14

**AXIAL PISTON FIXED DISPLACEMENT MOTOR**

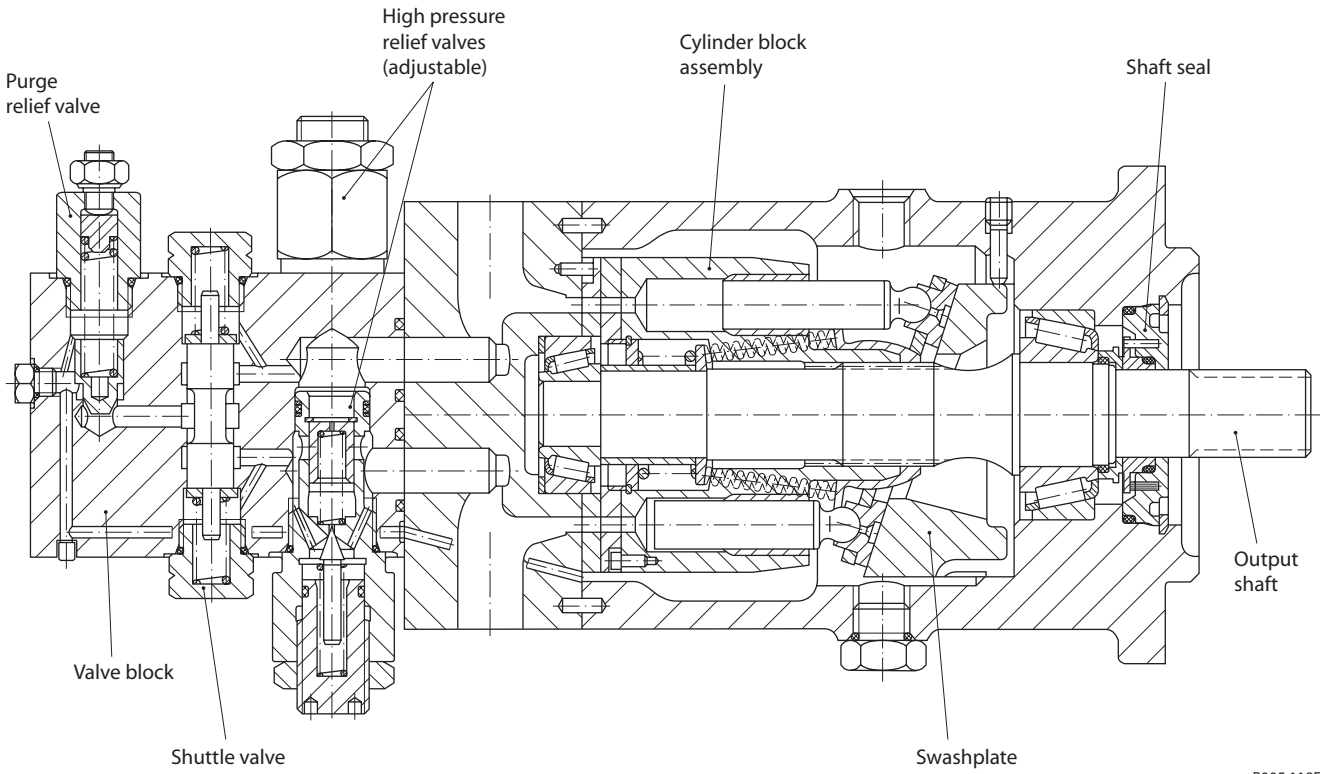

P005 118E

**PUMP AND MOTOR CIRCUIT DESCRIPTION**

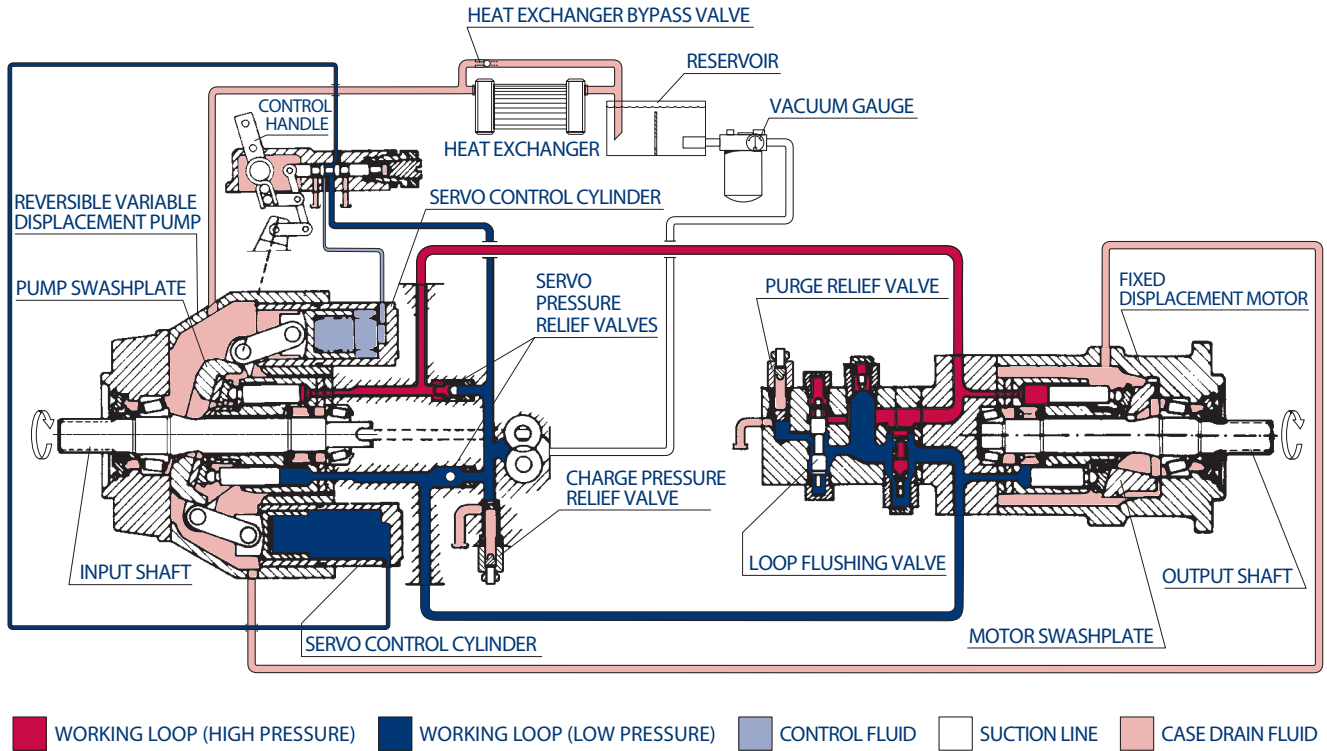

P000 027E

Above figure shows schematically the function of a hydrostatic transmission using an axial piston variable displacement pump and a fixed displacement motor.

**MOTOR CIRCUIT SCHEMATIC**

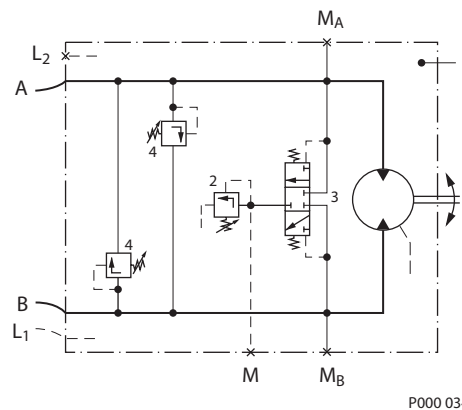

P000 034

Designation:

- 1 = Fixed displacement motor
- 2 = Purge relief valve
- 3 = Shuttle valve
- 4 = High pressure relief valve

Ports:

- A, B = Main pressure ports (working loop)
- L<sub>1</sub>, L<sub>2</sub> = Drain ports
- M<sub>A</sub> = Gauge port for port **A**
- M<sub>B</sub> = Gauge port for port **B**
- M = Gauge port - charge pressure

**TECHNICAL PARAMETERS Design**

Axial piston motor with fixed displacement and swash plate design.

**Type of mounting**

SAE four bolt flanges.

**Pipe connections**

Main pressure ports: SAE split flange

Remaining ports: SAE O-ring boss

**Direction of rotation and flow**

Clockwise or counterclockwise (viewing from the output shaft).

Direction of rotation	Port A	Port B
Clockwise (R)	Output	Input
Counterclockwise (L)	Input	Output

**Installation position**

Optional; motor housing must be always filled with hydraulic fluid.

**External drain fluid loss**

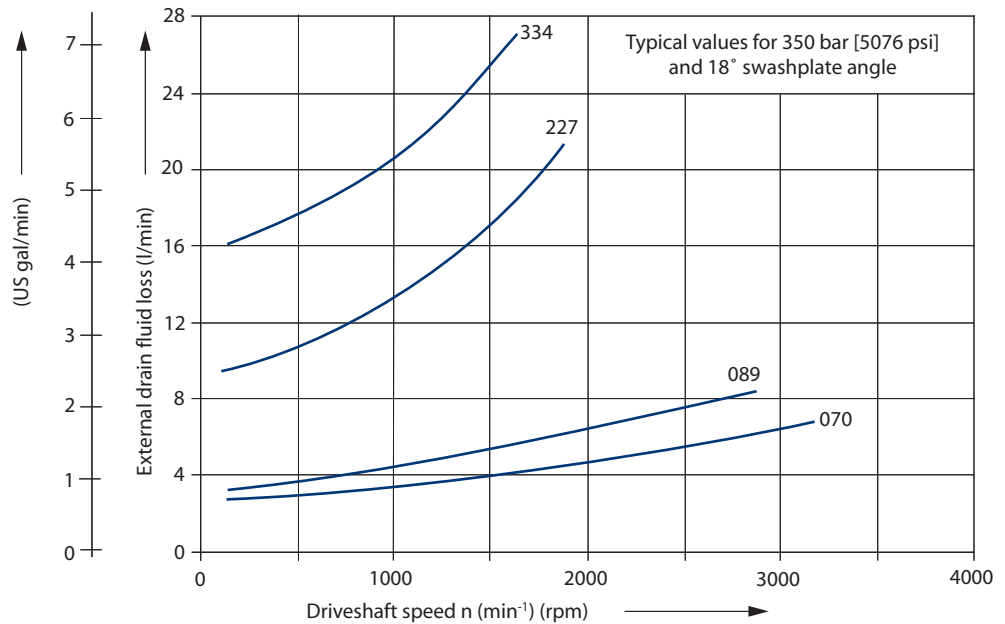

P005 105E

## HYDRAULIC PARAMETERS

### System pressure range, input $p_1$

Pressure on port A or B:

Max. operating pressure  $\Delta p = 420 \text{ bar [6092 psi]}$

Max. high pressure setting  $\Delta p = 460 \text{ bar}^1 \text{ [6672 psi]}$

<sup>1</sup>only with POR-valve

### System pressure range, output $p_2$

Normal setting for configuration MS and MR: 11.0 - 12.5 bar [160 - 181 psi] above case pressure.

Minimum: 8 bar, intermittent only

### Case pressure

Max. rated pressure = 2.5 bar [36.3 psi]

Intermittent = 5.0 bar [72.5 psi]

### Hydraulic fluid

Refer to Sauer-Danfoss publication *Hydraulic Fluids and Lubricants* and *Experience with Bio Fluids* for biodegradable hydraulic fluids.

### Hydraulic fluid temperature range

$\vartheta_{\min} = -40 \text{ °C [-40 °F]}$

$\vartheta_{\max} = 95 \text{ °C [203 °F]}$

### Viscosity range

$v_{\min} = 7 \text{ mm}^2/\text{s [49 SUS*]}$

$v_{\max} = 1000 \text{ mm}^2/\text{s [4630 SUS*]}$  (intermittent cold start)

Recommended viscosity range: 12 - 60  $\text{mm}^2/\text{s [66 - 278 SUS*]}$

\*SUS (Saybolt Universal Second)

### Filtration

Required cleanliness level: ISO 4406-1999 Code 22/18/13 or better.

Refer to Sauer-Danfoss publication *Hydraulic Fluids and Lubricants* and *Design Guideline for Hydraulic Fluid Cleanliness*.

### Shaft load

The pump will accept radial and axial loads on its shaft, the maximum capacity being determined by direction and point of application of the load.

Please contact your Sauer-Danfoss representative.

**HYDRAULIC  
 PARAMETERS  
 (continued)**

*Technical data*

		Frame size			
		070	089	227	334
Max. displacement	cm <sup>3</sup> [in <sup>3</sup> ]	69.8 [4.26]	89.0 [5.43]	227.3 [13.87]	333.7 [20.36]
Rated speed 1	min <sup>-1</sup> (rpm)	3200	2900	2100	1900
Theoretical torque	Nm/bar [in lb/1000 psi]	1.11 [677]	1.42 [867]	3.62 [2209]	5.31 [3240]
Mass moment of inertia of rotating group	kg m <sup>2</sup> · 10 <sup>-3</sup> [lbf·ft <sup>2</sup> · 10 <sup>-3</sup> ]	12.34 [292.8]	17.77 [421.7]	86.80 [2059.8]	161.40 [3830.0]

<sup>1</sup> for higher speeds contact your Sauer-Danfoss representative

**Determination of nominal motor size**

Unit:	Metric System:	Inch System
Input flow	$Q_e = \frac{V_g \cdot n}{1000 \cdot \eta_v}$ l/min	$Q_e = \frac{V_g \cdot n}{231 \cdot \eta_v}$ [gpm]
Output torque	$M_e = \frac{V_g \cdot \Delta p \cdot \eta_m}{20 \cdot \pi}$ Nm	$M_e = \frac{V_g \cdot \Delta p \cdot \eta_m}{2 \cdot \pi}$ [lbf·in]
Output power	$P_e = \frac{Q_e \cdot \Delta p \cdot \eta_t}{600}$ kW	$P_e = \frac{V_g \cdot n \cdot \Delta p \cdot \eta_t}{396\,000}$ [hp]
Speed	$n = \frac{Q_e \cdot 1000 \cdot \eta_v}{V_g}$ min <sup>-1</sup>	$n = \frac{Q_e \cdot 231 \cdot \eta_v}{V_g}$ (rpm)

Efficiency characteristic curves available on request.

$V_g$	= Motor displacement per revolution	cm <sup>3</sup>	[in <sup>3</sup> ]
$n$	= Motor speed	min <sup>-1</sup>	(rpm)
$\Delta p$	= Hydraulic pressure differential	bar	[psid]
	$\Delta p = p_{HD} - p_{ND}$		
$\eta_v$	= Motor volumetric efficiency		
$\eta_m$	= Motor mechanical efficiency		
$\eta_t$	= Motor total efficiency		
$p_{HD}$	= High pressure	bar	[psid]
$p_{ND}$	= Low pressure	bar	[psid]



**OUTLINE DRAWING,  
CONFIGURATION MS**

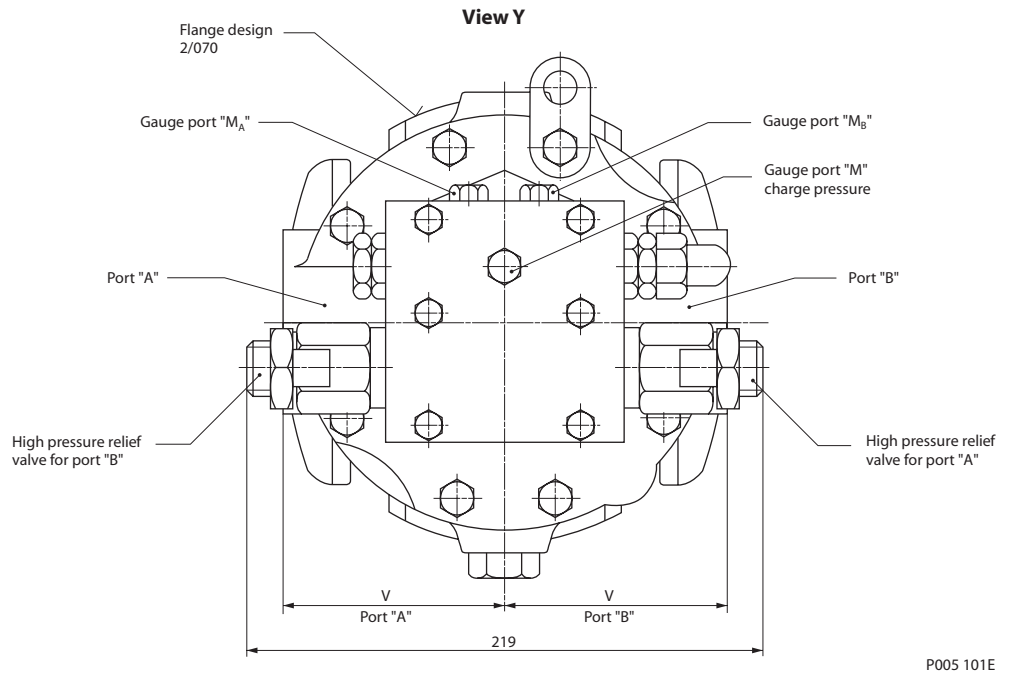
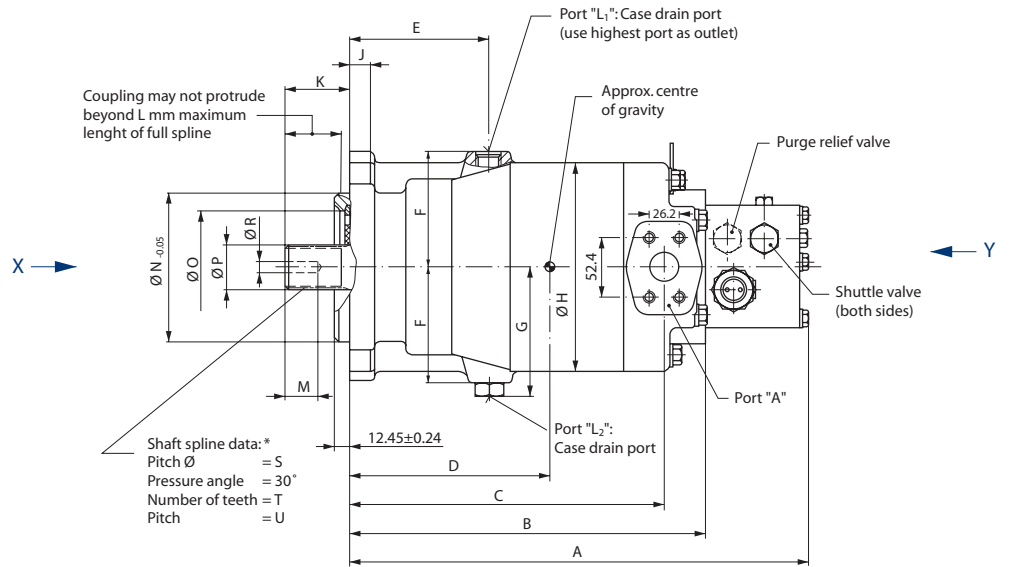

\* Shaft spline data: spline shaft with involute spline, according to SAE handbook, 1963, class 1, fillet root side fit.

Frame size	Port A and B	Port L <sub>1</sub> and L <sub>2</sub>	Port M <sub>A</sub> and M <sub>B</sub>	Port M
070	SAE flange, size 1 SAE split flange boss 5000 psi 4 threads	7/8-14 UNF-2B SAE straight thread O-ring boss	7/16-20 UNF-2B SAE straight thread O-ring boss	
089	3/8-16 UNC-2B 18 deep			

**OUTLINE DRAWING,  
CONFIGURATION MS  
(continued)**

**View X (for SMF 2/070 only)**

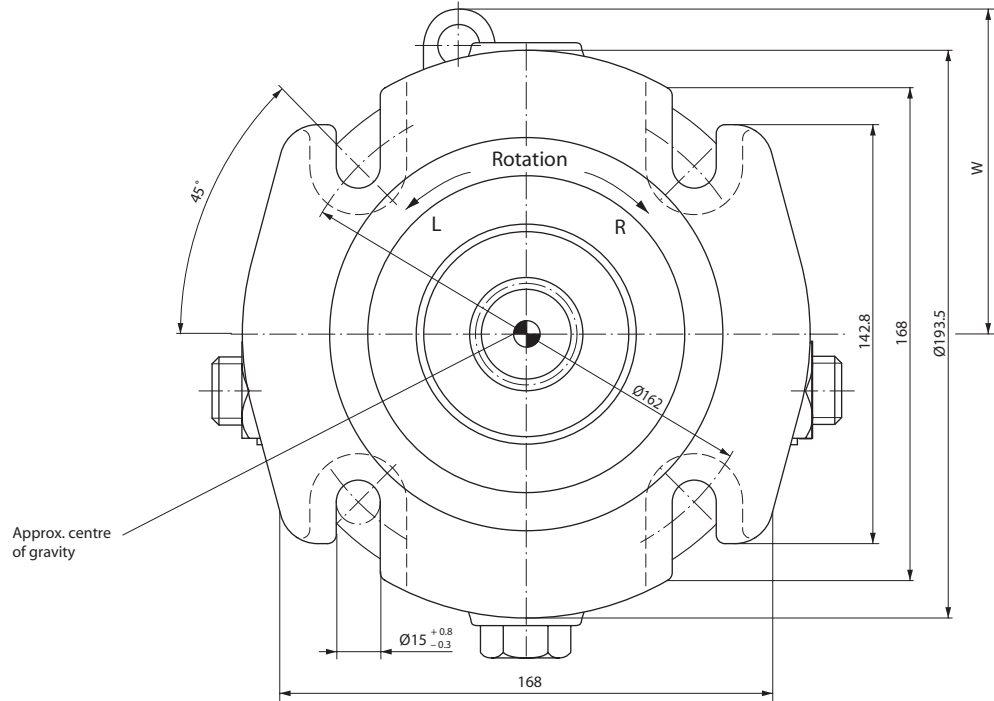

P005 119E

**View X (for SMF 2/089 only)**

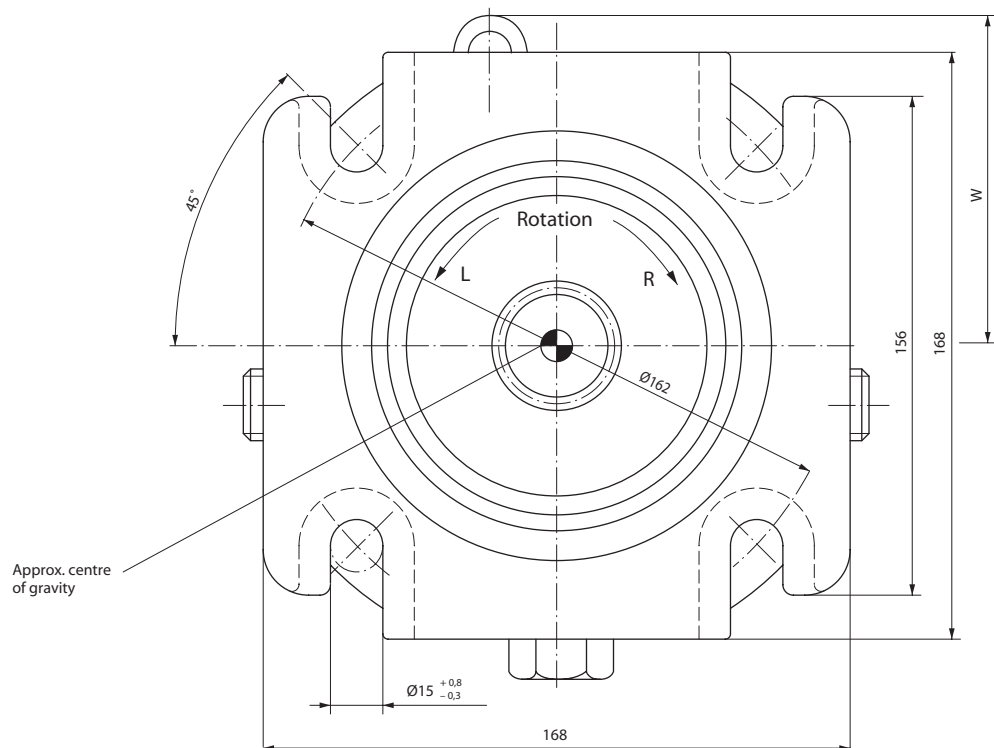

P005 120

**OUTLINE DRAWING, CONFIGURATION MS (continued)**

*Dimensions*

Frame size	A mm [in]	B mm [in]	C mm [in]	D mm [in]	E mm [in]	F mm [in]	G mm [in]	ØH mm [in]	J mm [in]	K mm [in]	L mm [in]	M mm [in]
070	378 [14.882]	290 [11.417]	255 [10.039]	165 [6.496]	108 [4.252]	86.5 [3.406]	98 [3.858]	161 [6.339]	16 [0.630]	56 [2.205]	48 [1.890]	28.4 [1.118]
089	395 [15.551]	307 [12.087]	273 [10.748]	170 [6.693]	118 [4.646]	96.0 [3.780]	107 [4.213]	181 [7.126]	18 [0.709]	56 [2.205]	48 [1.890]	28.4 [1.118]
Frame size	ØN mm [in]	ØO mm [in]	ØP mm [in]	ØR mm [in]	ØS mm [in]	T mm [in]	U mm [in]	V mm [in]	W mm [in]	Diameter for shaft coupling mm [in]	Weight kg [lb]	
070	127 [5.000]	84 [3.307]	34.50 <sup>-0.17</sup> [1.358 <sup>-0.0067</sup> ]	8.5 [0.335]	33.338 [1.313]	21 [0.827]	16/32	85.8 [3.378]	101 [3.976]	31.75 <sup>+0.062</sup> [1.250 <sup>+0.0024</sup> ]	40 [88]	
089	127 [5.000]	98 [3.858]	37.68 <sup>-0.17</sup> [1.483 <sup>-0.0067</sup> ]	8.5 [0.335]	36.513 [1.438]	23 [0.906]	16/32	95.2 [3.748]	114 [4.488]	34.95 <sup>+0.062</sup> [1.376 <sup>+0.0024</sup> ]	47 [104]	

**OUTLINE DRAWING, BASIC MODEL**

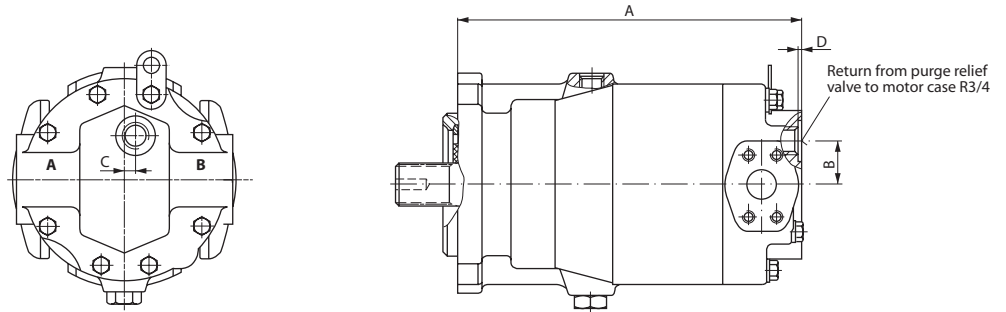

P000 568E

*Dimensions*

Frame size	A mm [in]	B mm [in]	C mm [in]	D mm [in]	Weight kg [lb]
070	290 [11.417]	30 [1.181]	12 [0.472]	2 [0.079]	34 [75]
089	307 [12.087]	44 [1.732]	6 [0.236]		41 [90]

For further dimensions see previous pages.

**OUTLINE DRAWING, MOTOR CONFIGURATION AM 01000**

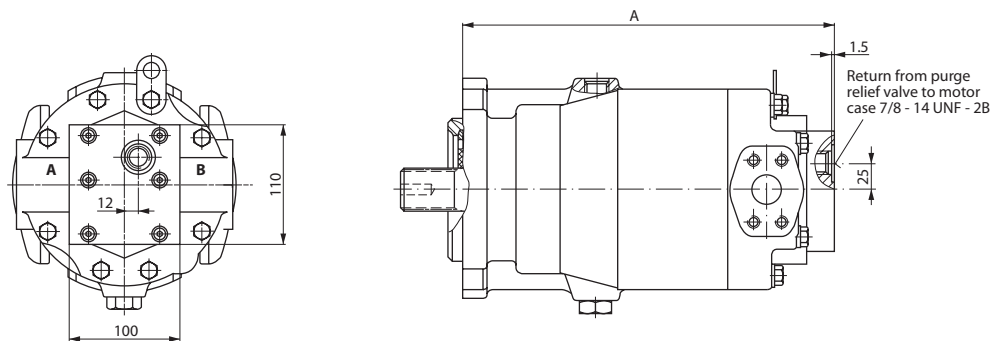

P000 569E

*Dimensions*

Frame size	A mm [in]	Weight <sup>1</sup> kg [lb]
070	315 [12.402]	36 [79]
089	332 [13.071]	43 [95]

<sup>1</sup> Light weight and short options available on request

For further dimensions see previous pages.

**OUTLINE DRAWING, MOTOR CONFIGURATION MR**

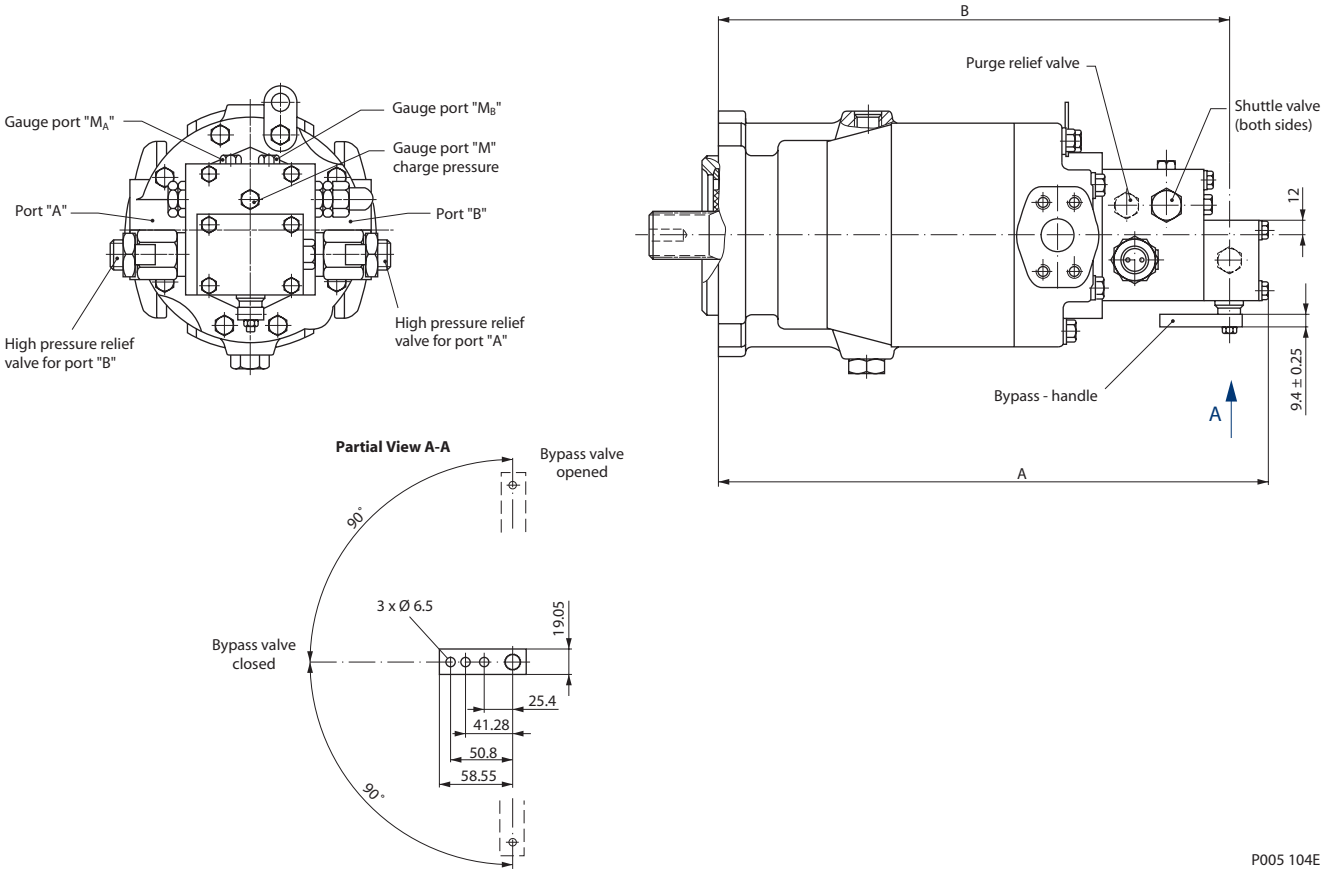

P005 104E

*Dimensions*

Frame size	A mm [in]	B mm [in]	Weight kg [lb]	Port M <sub>a</sub> and M <sub>b</sub>	Port M
070	426 [16.772]	391 [15.394]	42 [93]	7/16-20 UNF-2B SAE straight thread O-ring boss	
089	443 [17.441]	408 [16.063]	49 [108]		

For further dimensions see previous pages.

CIRCUIT DIAGRAMS

Configuration MR

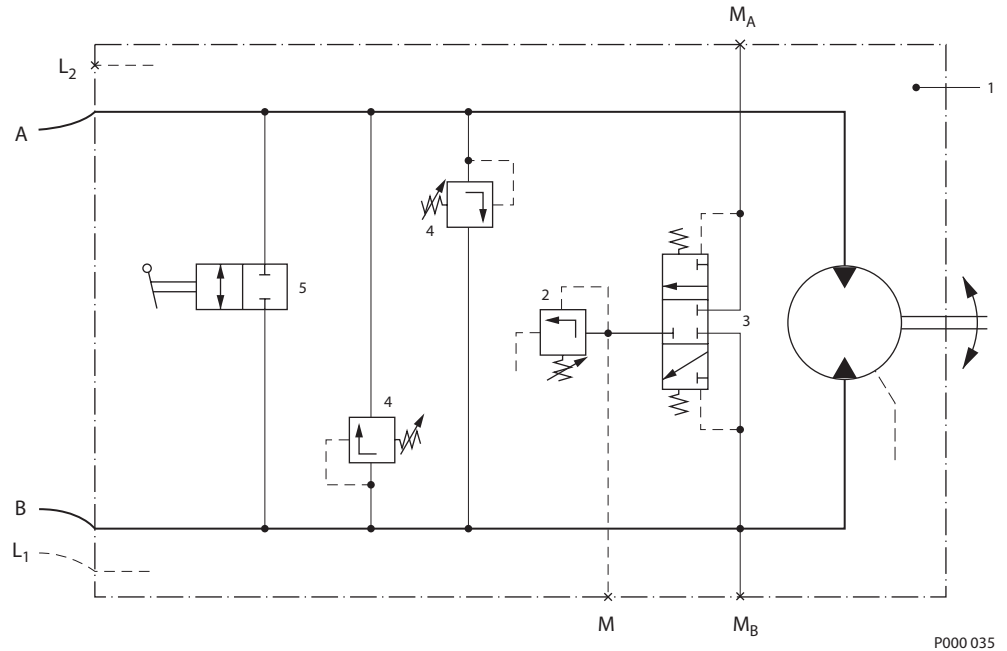

P000 035

Basic model and motor configuration AM 01000

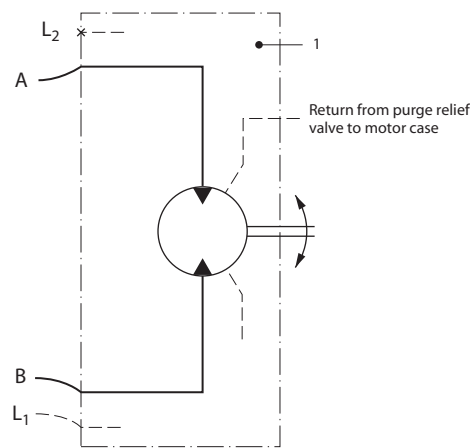

P000 038E

Designation:

- 1 = Fixed displacement motor
- 2 = Purge relief valve
- 3 = Shuttle valve
- 4 = High pressure relief valve
- 5 = Bypass valve

Ports:

- A,B = Main pressure ports (working loop)
- L<sub>1</sub>, L<sub>2</sub> = Drain ports
- M<sub>A</sub> = Gauge port for port **A**
- M<sub>B</sub> = Gauge port for port **B**
- M = Gauge port - charge pressure

**OUTLINE DRAWING, CONFIGURATION MS**

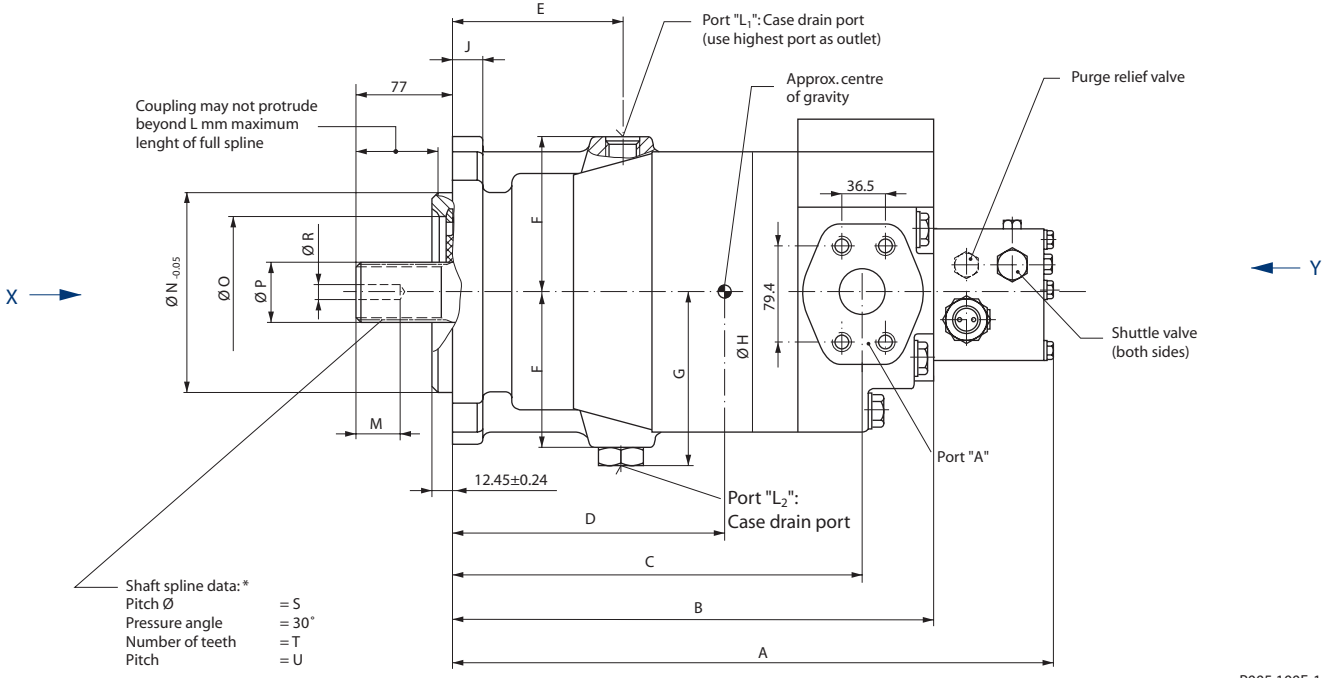

P005 100E-1

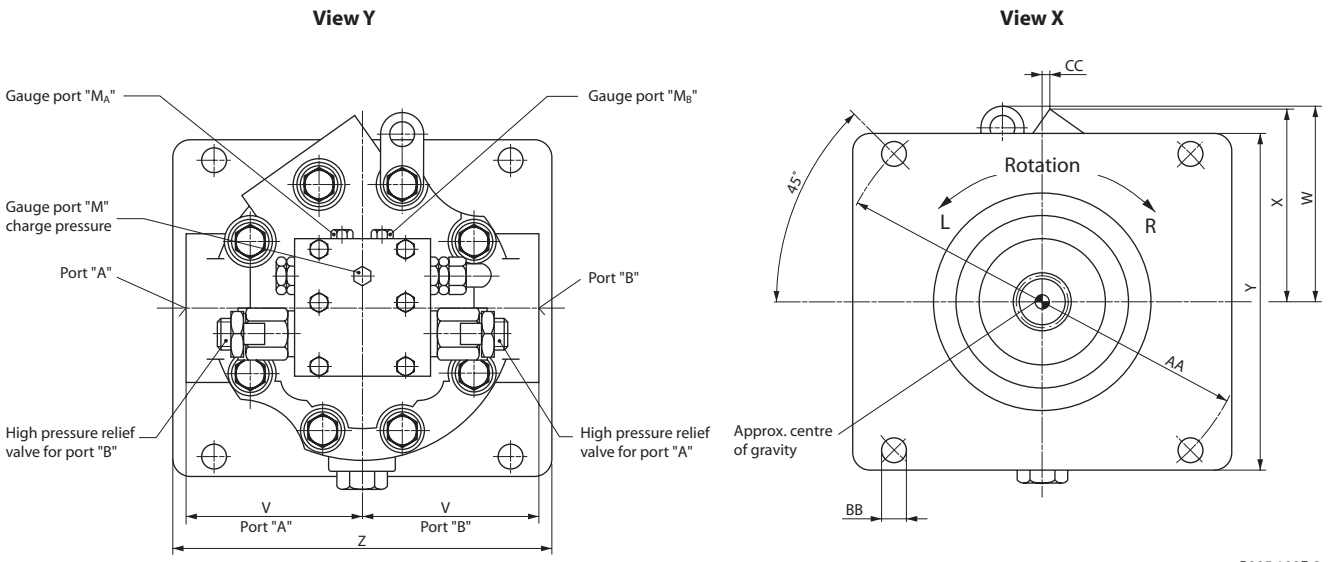

P005 100E-2

\* Shaft spline data: spline shaft with involute spline, according to SAE handbook, 1963, class 1, fillet root side fit.

**OUTLINE DRAWING,  
CONFIGURATION MS  
(continued)**

*Dimensions*

Frame size	A mm [in]	B mm [in]	C mm [in]	D mm [in]	E mm [in]	F mm [in]	G mm [in]	Ø H mm [in]	J mm [in]
227	498 [19.606]	410 [16.142]	346 [13.622]	228.5 [8.996]	139.7 [5.500]	134.9 [5.311]	152 [5.984]	264 [10.394]	27 [1.063]
334	537 [21.142]	449 [17.677]	389 [15.315]	278 [10.945]	154 [6.063]	143. [5.650]	161 [6.339]	292 [11.496]	38 [1.496]
Frame size	M mm [in]	Ø N mm [in]	Ø O mm [in]	Ø P mm [in]	Ø R mm [in]	Ø S mm [in]	T mm [in]	U mm [in]	V mm [in]
227	38.4 [1.512]	165.1 [6.500]	110 [4.331]	44.03 <sup>-0.17</sup> [1.733 <sup>-0.0067</sup> ]	11.80 [0.465]	42.863 [1.688]	27 [1.063]	16/32	143.7 [5.657]
334	46.2 [1.819]	177.8 [7.000]	114 [4.488]	64.66 <sup>-0.16</sup> [2.546 <sup>-0.0063</sup> ]	14.35 [0.565]	63.500 [2.500]	40 [1.575]	16/32	158.7 [6.248]
Frame size	W mm [in]	X mm [in]	Y mm [in]	Z mm [in]	AA mm [in]	BB mm [in]	CC mm [in]	Diameter for shaft coupling mm [in]	Weight kg [lb]
227	156 [6.142]	160 [6.299]	265 [10.433]	265 [10.433]	317.5 [12.500]	20.6 ± 0.4 [0.811 ± 0.0157]	13 [0.512]	41.28 <sup>+0.062</sup> [1.625 <sup>+0.0024</sup> ]	152 [335]
334	176 [6.929]	174 [6.850]	298 [11.732]	298 [11.732]	350 [13.780]	27.0 <sup>+0.5</sup> <sub>0.1</sub> [1.063 <sup>+0.0197</sup> <sub>-0.0039</sub> ]	18 [0.709]	61.93 <sup>+0.074</sup> [2.438 <sup>+0.0029</sup> ]	197 [434]

Frame size	Port A and B	Port L <sub>1</sub> and L <sub>2</sub>	Port M <sub>A</sub> and M <sub>B</sub>	Port M
227	SAE flange, size 1 1/2 SAE split flange boss 6000 psi 4 threads 5/8-11 UNC-2B 35 deep	1 7/8-12 UNF-2B SAE straight thread O-ring boss	7/16-20 UNF-2B SAE straight thread O-ring boss	
334				

## OUR PRODUCTS

Hydrostatic transmissions  
Hydraulic power steering  
Electric power steering  
Electrohydraulic power steering  
Closed and open circuit axial piston pumps and motors  
Gear pumps and motors  
Bent axis motors  
Orbital motors  
Transit mixer drives  
Planetary compact gears  
Proportional valves  
Directional spool valves  
Cartridge valves  
Hydraulic integrated circuits  
Hydrostatic transaxles  
Integrated systems  
Fan drive systems  
Electrohydraulics  
Microcontrollers and software  
Electric motors and inverters  
Joysticks and control handles  
Displays  
Sensors

## Sauer-Danfoss Mobile Power and Control Systems – Market Leaders Worldwide

Sauer-Danfoss is a comprehensive supplier providing complete systems to the global mobile market.

Sauer-Danfoss serves markets such as agriculture, construction, road building, material handling, municipal, forestry, turf care, and many others.

We offer our customers optimum solutions for their needs and develop new products and systems in close cooperation and partnership with them.

Sauer-Danfoss specializes in integrating a full range of system components to provide vehicle designers with the most advanced total system design.

Sauer-Danfoss provides comprehensive worldwide service for its products through an extensive network of Authorized Service Centers strategically located in all parts of the world.

Sauer-Danfoss (US) Company  
2800 East 13th Street  
Ames, IA 50010, USA  
Phone: +1 515 239-6000, Fax: +1 515 239 6618

Sauer-Danfoss (Neumünster) GmbH & Co. OHG  
Postfach 2460, D-24531 Neumünster  
Krokamp 35, D-24539 Neumünster, Germany  
Phone: +49 4321 871-0, Fax: +49 4321 871 122

Sauer-Danfoss (Nordborg) A/S  
DK-6430 Nordborg, Denmark  
Phone: +45 7488 4444, Fax: +45 7488 4400